

NOTE:
GASKET IS BLACK NITRILE.

21 LINKS OF 3/16" STAINLESS STEEL CHAIN
APPROX. 22" IN LENGTH

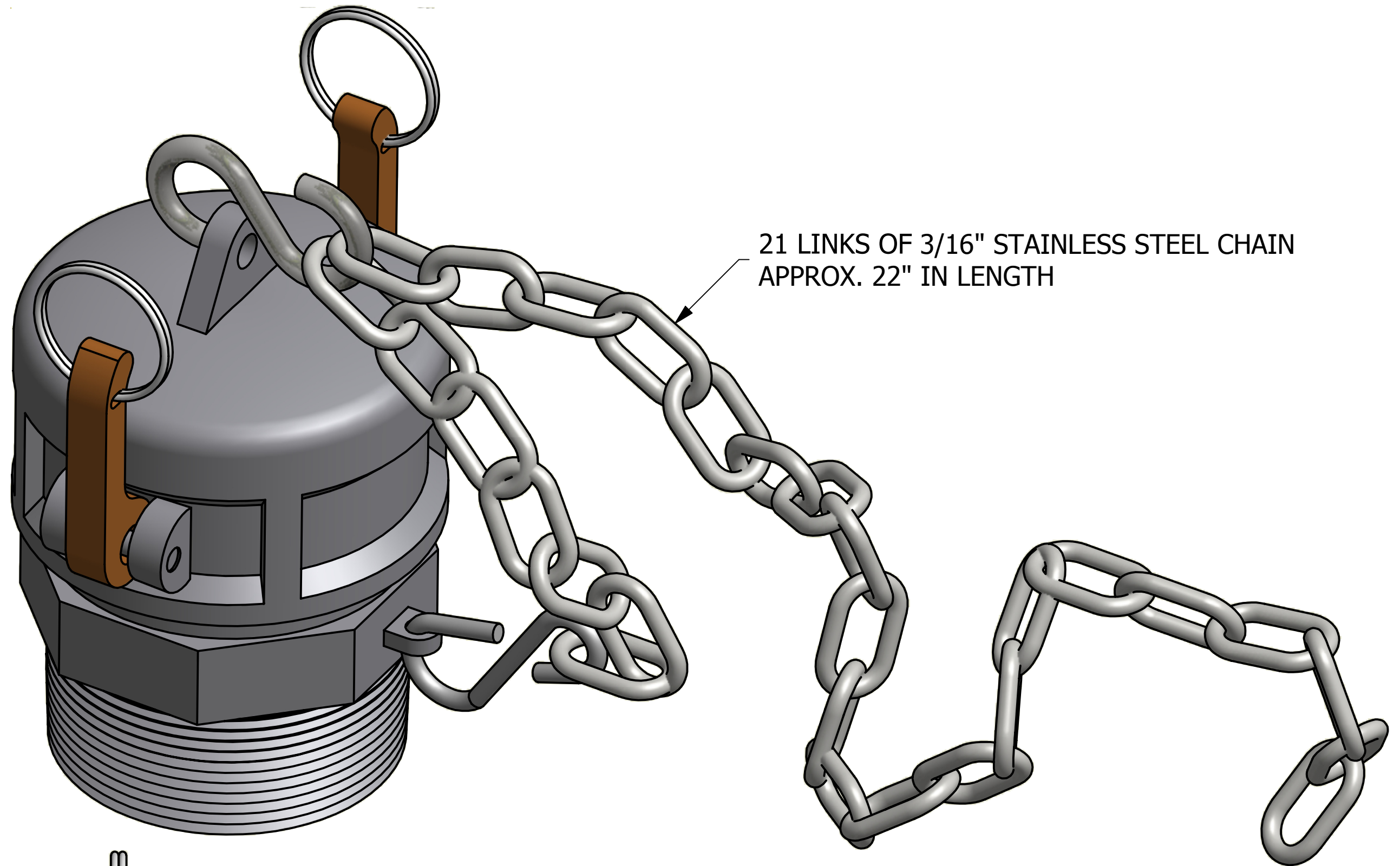

SALES DRAWING

SALES DRAWING

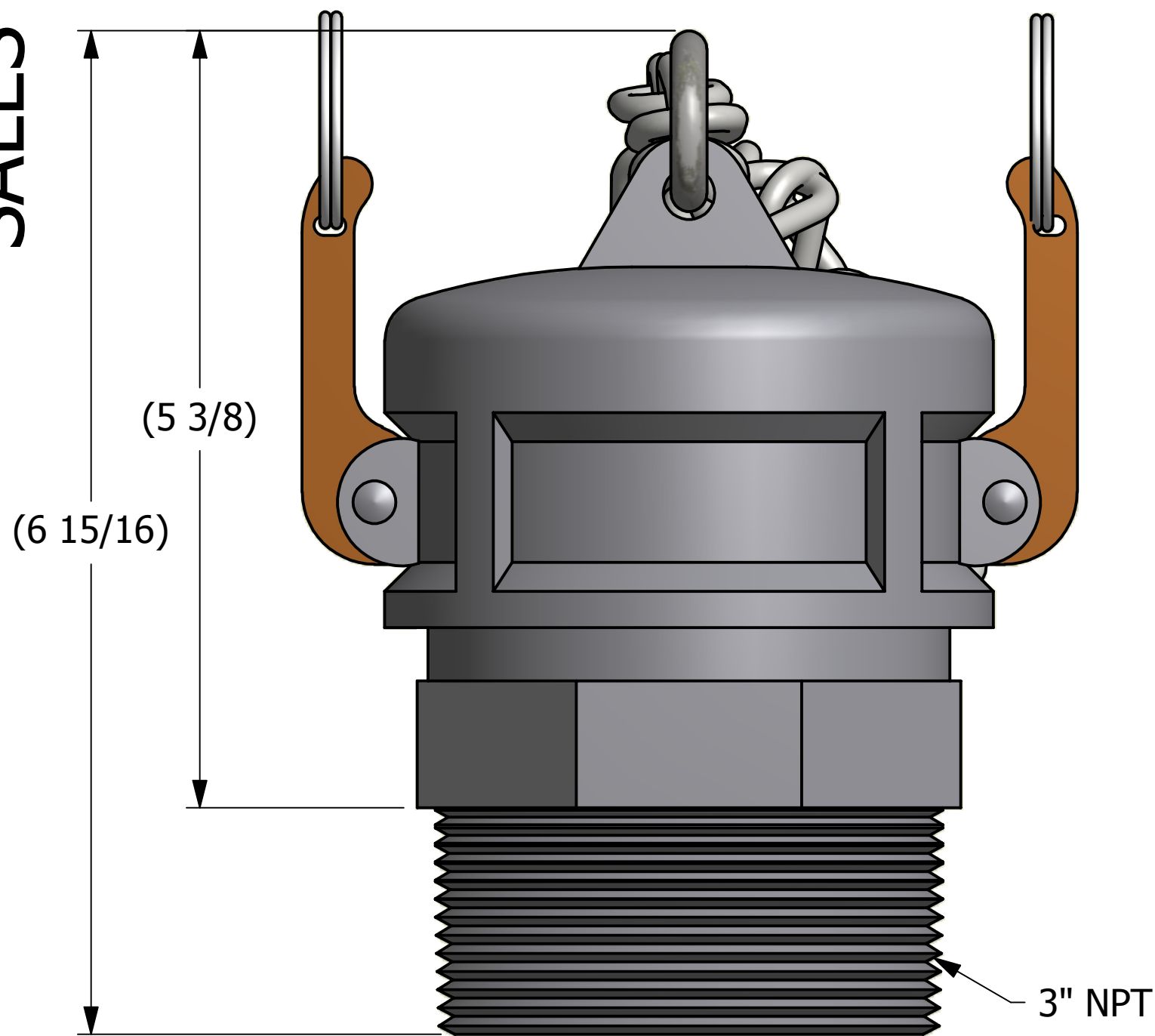

(5 3/8)
(6 15/16)

3" NPT

UNLESS OTHERWISE SPECIFIED
DIMENSIONAL TOLERANCES
FRACTIONAL: $\pm 1/16$
X.XX: $\pm .03$
X.XXX: $\pm .015$
ANGLE: $\pm 1^\circ$
DEBURR ALL SHARP EDGES.
ALL MACHINED SURFACES TO
HAVE A 125 RMS FINISH UNLESS
NOTED OTHERWISE.

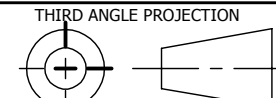

DRAWN BY: CHL
CHECKED BY: ACC
PROTOTYPE BY: CHL
PROTOTYPE DATE: 11/10/2011
APPROVED FOR PRODUCTION BY: ACC
PRODUCTION DATE: 1/24/2005

C	RJP	5-29-14	UPDATED K30IDC1A DESIGN
B	BG	11/10/11	K30IDC1A WAS K30IDC1
A	ACC	1-24-05	NEW PART ADDED TO THE NETWORK
REV	BY	DATE	DESCRIPTION

SALCO PRODUCTS, INC.

PART NAME: TOP FITTING ASSEMBLY 3" THREAD ON		
MATERIAL:	DUCTILE IRON	
PROJECT #:	WAG0182	SHEET #: 1 OF 1
DRAWING #:	C19948	SCALE: 1:1
PART #:	K30IUMP1A	